

Submittal Data: 18RLXFZH
Inverter Driven Heat Pump

18,000 BTU Multi Zone System

Job Name: _____

Date: _____

Location: _____

Approval: _____

Engineer: _____

Construction: _____

Submitted to: _____

Unit #: _____

Submitted by: _____

Drawing #: _____

Reference: _____

General Features

- Refrigerant Type R410A.
- Extra long piping allotment
- Wired and wireless remote controllers
- Automatic airflow adjustment
- Economy operation
- Base pan heater
- 5- Years Parts, 7-Years Compressor Warranty (See Warranty Statement for details)
- 24 hr. Timer
- Low operating temperature

Model Information

Condenser..... AOU18RLXFZH
 Evaporator*1..... (ASU) / (ARU) / (AGU) / (AUU) 7,9,12RLF(1)
 Connectable indoor units..... 2
 Total capacity range..... 14,000 – 21,000 Btu/h

Electrical..... 208/230V AC 1ph-60Hz
 Available Voltage Range..... 208/230 +/- 10%
 Minimum Circuit Ampacity..... 19.7 A
 Max Fuse Size..... 20 A
 Max Starting Current..... 7.9 A

Input Power

Cooling..... (non-duct) 1.33 kW / (ducted) 1.45 kW / (mix) 1.39 kW
 Heating..... (non-duct) 1.70 kW / (ducted) 1.79 kW / (mix) 1.74 kW

Current

Cooling..... (non-duct) 5.8 A / (ducted) 6.4 A / (mix) 6.1 A
 Heating..... (non-duct) 7.5 A / (ducted) 7.9 A / (mix) 7.7 A

Capacity

Nominal Cooling..... 18,000 Btu/h
 Min-Max Cooling..... 6,100 – 21,000 Btu/h
 Nominal Heating..... 22,000 Btu/h
 Min-Max Heating..... 6,800 – 24,400 Btu/h

Compressor

..... Rotary (inv x1)
 Motor Output..... 1,100 W
 Refrigerant..... R410a
 Charge..... 4 lbs. 3 oz
 Oil..... RB68

Fan Motor

(Condenser) Type: DC Propeller x1
 (Condenser) Motor Output..... 100 W
 (Evaporator) Type: DC..... (wall-mount) Cross flow
 (compact cassette) Turbo
 (ducted) Sirocco
 (floor) Cross flow x2
 (Evaporator) Motor Output..... (wall) 30W-42W (compact cassette) 54W (ducted) 80-81W

Heat Exchanger

Dimensions
 (H x W x D) in. (mm)..... 31-7/16 x 35-7/16 x 1-7/16 (798x900x36.38)
 Fin Pitch..... 20 FPI
 Rows x Stages..... 2 x 38
 Pipe Type (Material)..... Copper
 Fin Type (Material)..... Aluminum



Operation Temperature Range

Cooling..... 14°F - 115°F (-10°C - 46°C)
 Heating..... -15°F - 75°F (-26°C - 24°C)

Efficiency

SEER*2..... (wall-mount) 21.5 (duct) 19 (mix) 20.3
 EER (cooling)..... (wall-mount) 13.5 Btu/W (duct) 12.4 Btu/W (mix) 13 Btu/W
 COP (heating)..... (wall-mount) 3.79 W/W (duct) 3.60 W/W (mix) 3.70 W/W
 HSPF (heating)..... (wall-mount) 10.3 (duct) 9 (mix) 9.7

Enclosure (Condenser)

Material..... Painted galvanized steel
 Color..... Beige (10 YR 7.5/1.0 NN)

Sound Pressure Level

Condenser..... 48 dB(A)

Dimensions

H x W x D
 Condenser
 Net in. (mm)..... 32-11/16 x 35-7/16 x 13 (830x900x330)
 Gross in. (mm)..... 38-3/16 x 41-5/16 x 17-1/2 (970x1,050x445)

Connection Pipe

Liquid..... 1/4" x2
 Gas..... 3/8" x2
 Method (Liquid/Gas)..... Brazing
 Max Length (Pre-charge)..... 164ft. (50m) / (98 ft. {30m})
 Max Height Difference..... 49 ft. (15m)

Weight

Condenser..... 134 lbs. (61 kg)
 Evaporators..... (wall-mount) 19 lbs. - 31 lbs.
 (compact cassette) 33 lbs.
 (ducted) 37 lbs. - 49 lbs.
 (floor) 31 lbs.

Accessories

Wired Remote Controller..... UTY-RVNUM
 Wired Remote Controller..... UTY-RNNUM
 Simple Remote Controller..... UTY-RSNUM

*1 Reference brochure for approved combinations. *2 Test conditions are based on AHRI 210/240.
 Note: Specifications are based on the following conditions. Cooling: Indoor temperature of 80°F (26.7°C) DB/67°F (19.44°C) WB, and outdoor temperature of 95°F (35°C) DB/75°F (23.9°C) WB. Heating: Indoor temperature of 70°F (21.11°C) DB/59°F (15.°C) WB, and outdoor temperature of 47°F (8.33°C) DB/43°F (6.11°C) WB. Pipe length: 24ft. (7m). (7.5m). Height difference: 0ft. (0m) (Outdoor unit – indoor unit)

Dimensions: 18RLXFZH

[Unit: in. (mm)]

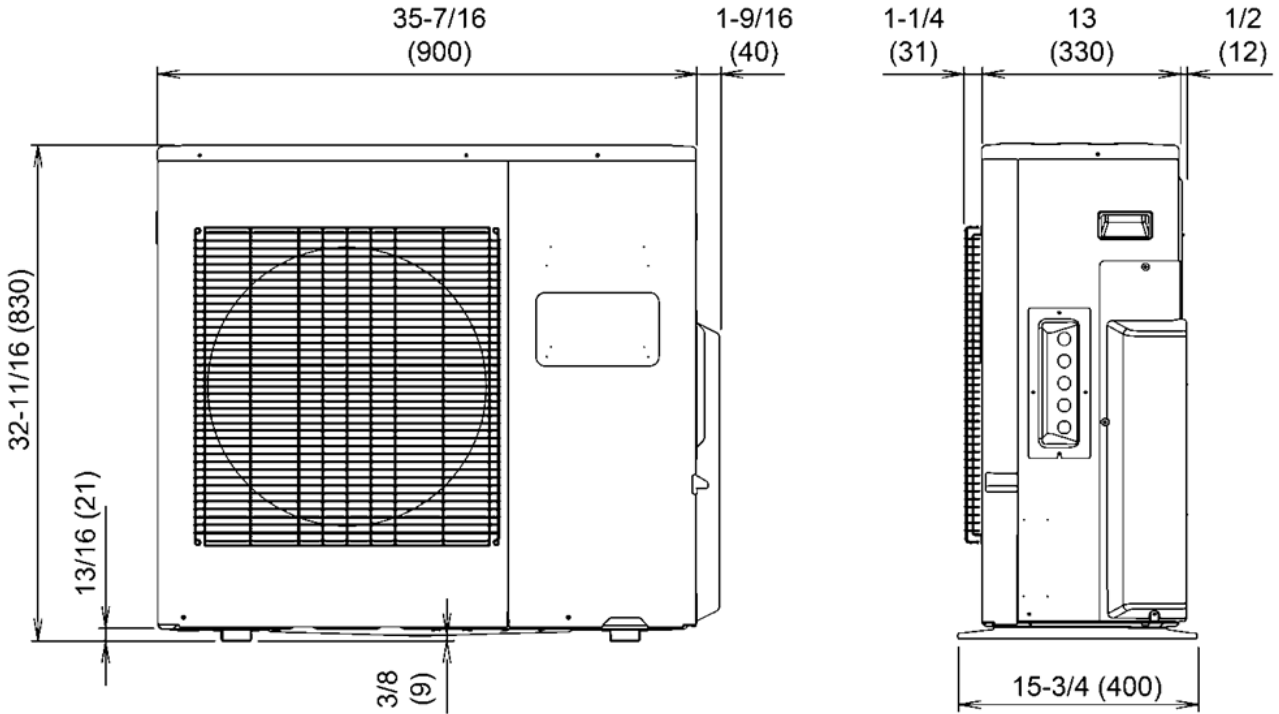

Front view

Side view

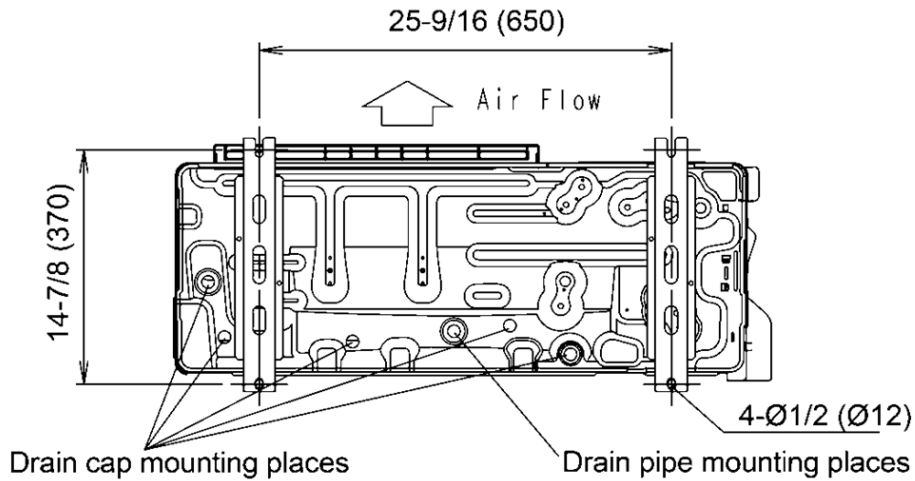

Bottom view